

## KCD-DA CO<sub>2</sub> Controller

Our CO<sub>2</sub> gas sensor with NDIR Dual Wavelength type gets a small deviation unlike NDIR Single Wavelength type.

Excellent stability and accuracy  
- through testing and calibration with sophisticated process and techniques

### Easy application to...

Environment management system  
Indoor ventilation system  
Air conditioning system  
Securing devices of combustors

- NDIR type uses optical property to measuring CO<sub>2</sub> gas.

We make up for a controller not to be affected by shock and wave(vibration).

But please consult with our engineers, if you use it under harsh environments (like construction sites).

Contact us if you have a question about installation or connection.

### • Detection method

- CO<sub>2</sub> : Dual Wavelength NDIR
- Temperature : NTC
- Humidity(Optional) : semiconductor type

**\* To detect temperature & humidity is option.**



### ■ SPECIFICATIONS

<b>Measure -ment</b>	Measuring range options	CO <sub>2</sub>	0~2,000ppm, 0~5,000ppm, 0~10,000ppm	
		Temperature	0~60 °C	
		Humidity	0~99% RH	
	Accuracy (@25 °C)	CO <sub>2</sub> *	±(4%FS+3%Reading)	
		Temperature	±2 °C	
		Humidity	±3 %	
Response time (τ <sub>63</sub> )	CO <sub>2</sub>	< 30 sec		
	Temperature, Humidity	< 10 sec		
	Measurement time interval	1.5 sec		
<b>General</b>	Warm up time	CO <sub>2</sub>	< 3 min	
		Temperature, Humidity	< 30 sec	
	Storage temperature	-40~70 °C		
	Weight	< 150g		
<b>Operating Conditions</b>	CO <sub>2</sub> , Humidity	Temperature	5~45 °C	
		Humidity	0~95%RH (Non-condensing)	
	Temperature	Temperature	0~60 °C	
		Humidity	0~95%RH (Non-condensing)	
<b>Electrical</b>	Power supply	24V AC/DC (< ±20%)		
	Power consumption	70mA average		
<b>Outputs</b>	CO <sub>2</sub>	0~10VDC or 4~20mA, RS485, Relay SPST		
	Temperature, Humidity	0~10VDC or 4~20mA		

\* Under conditions of calibration facilities of production factory, @25 °C, intermediate value of detected ranges.  
\* Specifications and images may change without prior notice.

# KCD-DA

## CO<sub>2</sub> Controller

### ■ Connectors

#### 1. Diagram

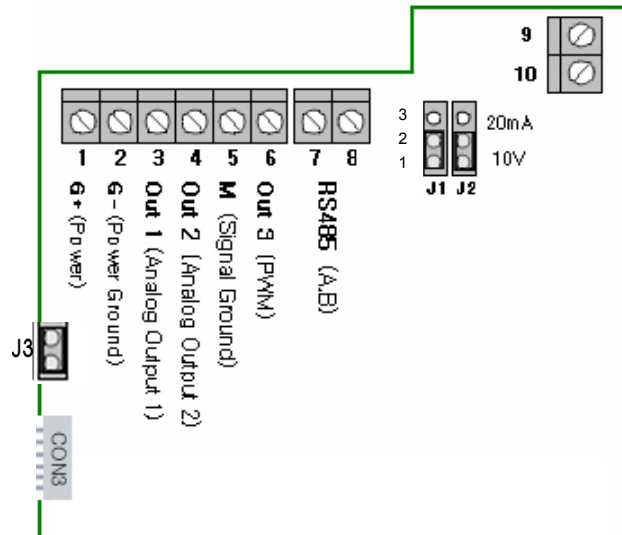

#### 2. Input · Output specification

Terminal	Description	Notes
1	G+	Power (+) 24 V AC/DC ±20% System Power
2	G-	
3	Out 1	Signal Output (+) 1 10V/20mA : 0~2000ppm(Default) Output error : FS ±2%
4	Out 2	Signal Output (+) 2 10V/20mA : 0~50℃ , Humidity 50%, VOC 1 ~ 10 Level Output error : FS ±2%
5	M	Signal Ground (-)
6	Out 3	Open Collector ON/OFF PWM output (1004 msec interval) ON : 1,000ppm, OFF: 800ppm 1004msec interval, 2msec Duty
7	RS485A	RS-485
8	RS485B	
9	RLY 1,	Relay contacts ON : 1,000ppm, OFF: 800ppm(Default)
10	RLY 2	

#### 3. Jumper to set output way

- Jumper 1 : Select OUT1 output way (1,2:Voltage output, 2,3:Current output)
- Jumper 2 : Select OUT2 output way (1,2:Voltage output, 2,3:Current output)
- Jumper 3 : For using RS485, It have to be shorted.

※ Do not use CON3(it is for PC monitoring).



Misuse causes system malfunction and breakdown of a controller.

# KCD-DA

## CO2 Controller

### ■ Operation

#### 1. Buttons

- **MENU**  : Selecting setting items (CO2, VOC, temperature, humidity and others)
- **UP**  : Increase set points or YES
- **DOWN**  : Decrease set points or NO.

A LCD window shows sings as following order each time you press MENU button

No.	Initial sings	Descriptions	Sings by press ▲ ▼ & others
0	****ppm	Operating status	Normal or Error
1	DISP	Setting main display on LCD	▲ CO2(Default) ▼ VOC
2	CO2ON	Setting the CO2 concentration for relay contacts ON	1000 ppm (Default) : Relay ON Point (▲,▼ : Increase/decrease 50ppm by pressing buttons)
3	CO2OF	Setting the CO2 concentration for relay contacts OFF	800 ppm (Default) : Relay OFF Point (▲,▼ : Increase/decrease 50ppm by pressing buttons)
4	OC-ON	Setting VOC Level for relay contacts ON	4 Level (Default) : Relay ON Point (▲,▼ : Increase/decrease 1 level by pressing buttons)
5	OC-OFF	Setting VOC Level for relay contacts OFF	2 Level (Default) : Relay OFF Point (▲,▼ : Increase/decrease 50ppm by pressing buttons)
6	T-USE	Selecting temperature sensing function (Yes / No)	YES(Default) : Measure temperature NO
7	H-USE	Selecting humidity sensing function (Yes / No)	YES(Default) : Measure humidity NO
8	RANGE	Setting maximum measuring ranges of CO2	(▲:Increase, ▼:Decrease) 0 : 2,000ppm (Default) 1 : 5,000ppm 2 : 10,000ppm
9	OUT2S	Selecting an output sensor through OUT2	(▲:Increase, ▼:Decrease) 0 : Temperature(Default) (▲:Increase, ▼:Decrease) 1 : Humidity 2 : VOC
10	R-OUT	Selecting Relay output sensor	▲ CO2 (Default) ▼ VOC
11	RTIME	Time setting for relay contact ON	(▲:Increase, ▼:Decrease) Default : 5 minutes 1min~40min setting available
12	OUT-1	Setting OUT1(CO2) output	▲ V-OUT(Default) : 0V~10V ▼ C-OUT : 4mA~20mA
13	OUT-2	Setting OUT2 output	▲ V-OUT(Default) : 0V~10V ▼ C-OUT : 4mA~20mA
14	OUT-3	Setting OUT3(CO2) output	▲ PULSE(Default) : PWM output ▼ O-C : On/Off
15	C-F	Selecting a sign of temperature (°C / °F)	▲ °C (Default) : ▼ °F
16	CALCO	Setting calibration value of CO2	▲ : +50ppm ▼ : -50ppm

# KCD-DA

## CO<sub>2</sub> Controller

17	CALOC	Setting calibration value of VOC
18	CAL-T	Setting calibration value of Temperature
19	CAL-H	Setting calibration value of Humidity
20	MD-ID	Setting Module ID

### 2. Additional information

1) If there is no input for 3 seconds after press **MENU**, a display turns into set points. After this, if there is no input for 3 seconds too, it turns into Main display.

2) CO<sub>2</sub> ON, OFF setting ranges depend on Measuring ranges as follows.

Measuring ranges	CO <sub>2</sub> ON setting ranges	CO <sub>2</sub> OFF setting ranges
2,000ppm	200ppm ~ 2,000ppm	100ppm ~ 1,900ppm
5,000ppm	200ppm ~ 4,000ppm	100ppm ~ 3,900ppm
10,000ppm	200ppm ~ 8,000ppm	100ppm ~ 7,900ppm

\* Increase/decrease 50ppm each time ▲, ▼ buttons are pushed.

3) Relay & OUT3 output function

: Press UP(▲) DOWN(▼) key at the same time for 3 sec, relay contacts ON regardless of set points during certain time.

4) If you redo 3) function, you should wait about 30 seconds –set delay interval.

### 3. LED

- 1) Power LED : Display Power ON/OFF status
- 2) OUT LED : Display RELAY ON/OFF status

### 4. Display errors

- 1) Errors of a temperature sensor : tHSt  
(temperature sensor Short) / tHoP(temperature sensor OPEN)
- 2) Errors of a humidity sensor : HUST  
(humidity sensor Short), / HUoP(humidity sensor OPEN)

### ■ RS485 Communication

#### • RS-485 communication protocol

1) Communication Mode ASYNC  
(UART : Universal Asynchronous Receiver Transmitter)

2) Communication data type

BAUD RATE : 9600bps

Data Bits : 8 bit

Parity Bit : no

Stop Bit : 1 bit

3) For defined communication protocol, refer to the additional documents.

# KCD-DA

## CO<sub>2</sub> Controller

■ **Dimensions** (Length × Width × Height) : 123mm × 80 mm× 29 mm

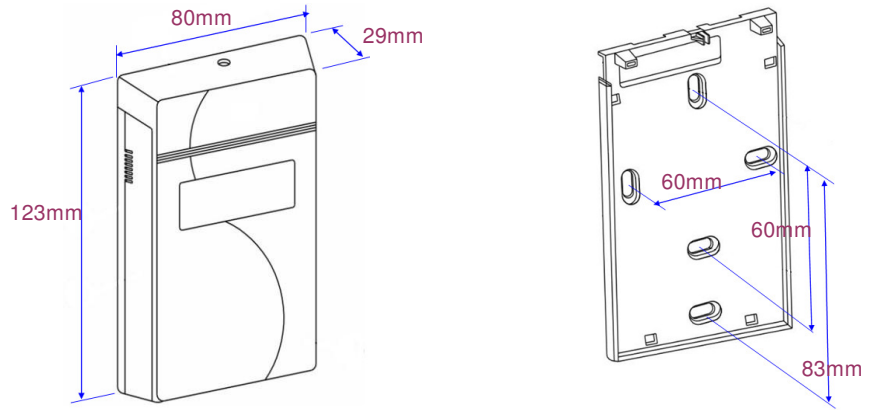

### Warranty and Instructions

#### ■ Warranty

This product passes our strict quality control and Korea Digital will repair or replace without charge this item within 1 year after sale except for damage or break by customer's mistake.

#### ■ Instructions

1. Caution: shock and moisture
  - 1) The characters of NDIR optical system may be changed by impacts.  
Don't give it heavy impacts.  
And be careful not to drop this controller.
  - 2) Don't use it where water drops and condensation can occur, too.
2. Keep operating conditions written above. If you do not, it may break down or have large errors.